



**CAUTION**  
RISK OF ELECTRIC SHOCK  
DO NOT OPEN



**CAUTION** : TO REDUCE THE RISK OF ELECTRIC SHOCK  
DO NOT REMOVE COVER (OR BACK)  
NO USER SERVICEABLE PARTS INSIDE  
REFER SERVICING TO QUALIFIED  
SERVICE PERSONNEL  
  
REFER SERVICING TO QUALIFIED SERVICE PERSONNEL.



The lightning flash with an arrowhead symbol within an equilateral triangle is intended to alert the user to the presence of uninsulated dangerous voltage within the product's enclosure that may be of sufficient magnitude to constitute a risk of electric shock to persons.



The exclamation point within an equilateral triangle is intended to alert the user to the presence of important operating and maintenance (servicing) instructions in the literature accompanying the product.

**FCC WARNING** - This equipment may generate or use radio frequency energy. Changes or modifications to this equipment may cause harmful interference unless the modifications are expressly approved in the instruction

manual. The user could lose the authority to operate this equipment if an unauthorized change or modification is made.

#### REGULATORY INFORMATION : FCC Part 15

This equipment has been tested and found to comply with the limits for a Class B digital device, pursuant to Part 15 of the FCC Rules. These limits are designed to provide reasonable protection against harmful interference when the equipment is operated in a commercial environment. This equipment generates, uses, and can radiate radio frequency energy and, if not installed and used in accordance with the instruction manual, may cause harmful interference to radio communications. Operation of this equipment in a residential area is likely to cause harmful interference in which case the user will be required to correct the interference at his own expense.

- A suitable conduit entries, knock-outs or glands shall be provided in the cable entries of this product in the end use

- Holes in metal, through which insulated wires pass, shall have smooth well rounded surfaces or shall be provided with brushings.

**WARNING** - Do not install this equipment in a confined space such as a bookcase or similar unit.

**WARNING** - Wiring methods shall be in accordance with the National Electric Code, ANSI/NFPA 70.

**WARNING** - This is a class A product. In a domestic environment this product may cause radio interference in which case the user may be required to take adequate measures.

**WARNING** - To reduce a risk of fire or electric shock, do not expose this product to rain or moisture.

**CAUTION** - This installation should be made by a qualified service person and should conform to all local codes.

**CAUTION** - To avoid electrocal shock, do not open the cabinet. Refer servicing to qualified personnel only.

**CAUTION** - To apparatus should not be exposed to water (dripping or splashing) and no objects filled with liquids, such as vases, should be placed on the apparatus.



#### Disposal of your old appliance

1. When this crossed-out wheeled bin symbol is attached to a product it means the product is covered by the European Directive 2002/96/EC
2. All electrical and electronic products should be disposed of separately from the municipal waste stream via designated collection facilities appointed by the government or the local authorities
3. The correct disposal of your old appliance will help prevent potential negative consequences for the environment and human health
4. For more detailed information about disposal of your old appliance, please contact your city office, waste disposal service or the shop where you purchased the product.

To disconnect power from the mains, pull out the mains cord plug. When install the product, ensure that the plug is easily accessible.

## IMPORTANT SAFETY INSTRUCTIONS

- 1. Read these instructions** - All these safety and operating instructions should be read before the product is operated.
- 2. Keep these instructions** - The safety, operating and user instructions should be retained for future reference.
- 3. Heed all warnings** - All warnings on the product and in the operating instructions should be adhered to.
- 4. Follow all instructions** - All operating and user instructions should be followed.
- 5. Do not use this apparatus near water** - For example : near a bath tub, wash bowl, kitchen sink, laundry tub, in a wet basement; near a swimming pool; etc.
- 6. Clean only with dry cloth** - Unplug this product from the wall outlet before cleaning. Do not use liquid cleaners.

- 7. Do not block any ventilation openings. Install in accordance with the manufacturer's instructions.** - Slots and openings in the cabinet are provided for ventilation, to ensure reliable operation of the product, and to protect it from overheating. The openings should never be blocked by placing the product on a bed, sofa, rug or other similar surface. This product should not be placed in a built-in installation such as a bookcase or rack unless proper ventilation is provided and the manufacturer's instructions have been adhered to.
- 8. Do not install near any heat sources such as radiators, heat registers, stoves, or other apparatus (including amplifiers) that produce heat.**

- 9. Protect the power cord from being walked on or pinched particularly at plugs, convenience receptacles, and the point where they exit from the apparatus.**
- 10. Only use attachments/accessories specified by the manufacturer.**



- 13. Unplug this apparatus during lightning storms or when unused for long periods of time.**

## IMPORTANT SAFETY INSTRUCTIONS

- 14. Refer all servicing to qualified service personnel.** Servicing is required when the apparatus has been damaged in any way, such as powersupply cord or plug is damaged, liquid has been spilled or objects have fallen into the apparatus, the apparatus has been exposed to rain or moisture, does not operate normally, or has been dropped.

FEATURES.....	7p	MENU DETAILS.....	17p
MODEL SELECTION.....	8p	1. General Setup.....	17p
PART NAMES.....	9p	2. Camera Setup.....	18p
SET POSITION.....	10p	3. Memory Function.....	29p
CONNECTIONS.....	11p	4. Special Function.....	33p
INSTALLATION.....	13p	5. Factory Default.....	34p
ACCESSORIES AND OTHERS.....	14p	6. Exti Setup.....	34p
OSD WORKING.....	15p	SPECIFICATIONS.....	35p
1. Entering Main menu.....	15p		
2. Moving to Sub-menu.....	16p		
3. Exiting from Main-menu.....	16p		

**This color video camera is designed for use in monitoring systems.**

- IP67 Rating, Aluminum Die-casting Rugged Vandal Proof Camera
- Wall or Ceiling Mounting through internal 3-Axis camera bracket
- Flush/Surface mountable using the supplied mount adaptor box
- Safety strap holds dome cover in place while making adjustments
- Fits over standard 2-gang box
- SONY 1/3" Super HAD CCD
- High Resolution of 540 TV Lines
- Day & Night Capability with High Sensitivity of 0.0001Lux
- Vari-focal Lens : 2.8~10mm
- Mechanical IR Cut Filter Removable(TDN) : 24pcs IR Optional
- Honeywell ISP, iCORE
- BLC / BMB / WDR Function
- Privacy Zone Masking : 8Zones
- Digital 1~16x zoom
- Easy Operation via On Screen Display
- Extra Video Out On OSD Board

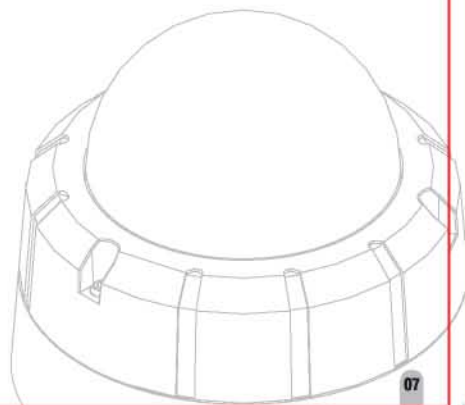

# MODEL SELECTION

## Vandal Dome Camera

CCD	KEY FEATURE	MODEL	H.Resolution
1/3" Super HAD	Varifocal lens(FUJINON) f=2.8~10mm, without TDN, NTSC	HVD-890NV	540TV Line
1/3" Super HAD	Varifocal lens(FUJINON) f=2.8~10mm, with TDN, NTSC	HVD-890NT	540TV Line
1/3" Super HAD	Varifocal lens(FUJINON) f=2.8~10mm, with TDN, IR LED, NTSC	HVD-890NI	540TV Line
1/3" Super HAD	Varifocal lens(FUJINON) f=2.8~10mm, without TDN, PAL	HVD-890PV	540TV Line
1/3" Super HAD	Varifocal lens(FUJINON) f=2.8~10mm, with TDN, PAL	HVD-890PT	540TV Line
1/3" Super HAD	Varifocal lens(FUJINON) f=2.8~10mm, with TDN, IR LED, PAL	HVD-890PI	540TV Line

# PART NAMES

## VANDAL HOUSING

### Normal Type

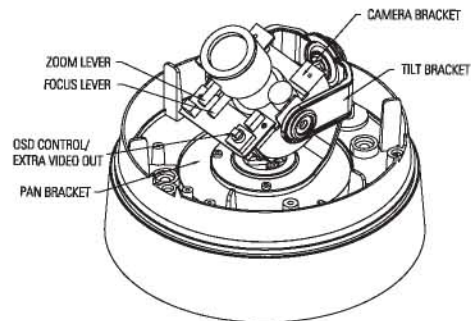

### IR Type

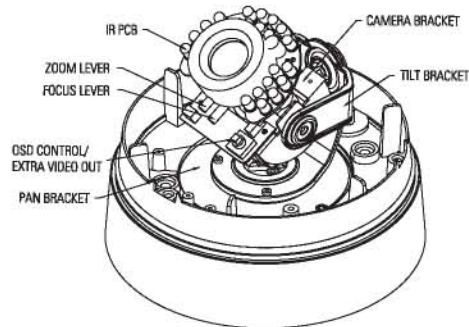



## SET POSITION

### Set Camera DIRECTION (3-axis movement)

#### Ceiling Type

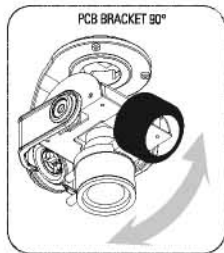
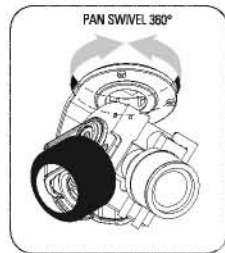
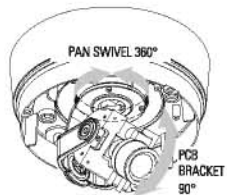

#### Wall Type

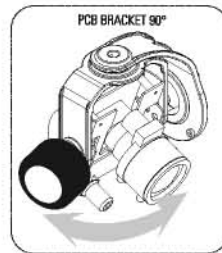
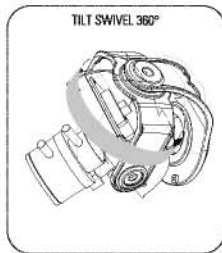
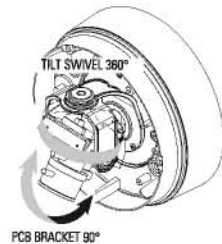

## CONNECTIONS

### DC 12V power Input

- Connect the video out jack to the video in jack monitor
- Connect the adapter to the power input connector
- Use a DC12V and 500mA adapter

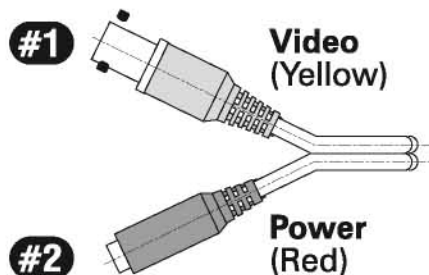

### Video Output



No.	Function	Terminal Color
#1	Video Out	Yellow
#2	Power Input	Red

## CONNECTIONS

### IMPORTANT REMINDER:

- For outdoor applications, please seal carefully with included rubber ring and machine screws (4 screws).

The 4 screws holes must be sealed completely using the supplied machine screws with rubber rings.

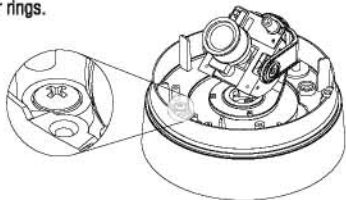

### - DOME/WINDOW CARE

- 1) Handle the dome carefully to prevent scratching. If a scratch appears over the lens you can turn the dome to move the scratch out of view.

### - Power supply

- 1) To avoid fire or shock hazard, must use a UL listed power supply.

### - Monitor Impedance

- 1) Set the impedance switch to a 75Ω standard position.
- 2) When the monitor is set to high impedance mode, the picture may become blurred. In this case, check the position of monitor impedance switch.

### Caution!

- \* Please keep dome cover and camera lens clean for better picture.
- \* To avoid smearing, do not directly expose the camera lens to strong light source such as the sun or spot lights.

## INSTALLATION

The camera can be installed on a junction box or directly on the wall/ceiling.

1. Attach the surface mount bracket to the ceiling using the (4) mount screws.
2. Draw out and position the power/video wires for connection
3. Connect the dome base to the surface mount bracket using the screws with rubber rings(see p.13)
4. Adjust the image by using the focus and zoom lever.
5. Place the dome cover over the base and adjust the cover shield
6. Secure the dome cover to the base using the L-wrench.

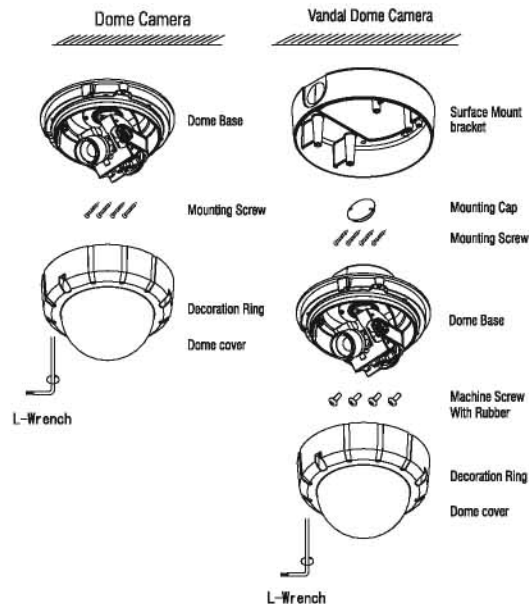

## Vandal Dome Accessories



Mount Screw with O-ring



Machine Screw with O-ring



User's Manual



Extra video out cable

## Brackets Optional

### Vandal Dome Bracket



<< GENERAL SETUP >>

**SYNC**                    **128**

**BURST**                 **128**

**CONTRAST**           **50**

**RETURN**

## 1. Entering Main menu

- If you press ENTER button for more than 2sec then menu will appear on the monitor.
- If you press LEFT button then cursor will move to previous icon, and if you press RIGHT button then cursor will move to next icon. Selected icon will be shown as colored.
- If there is no input for a long time, menu will disappear automatically.

## 2. Moving to Sub-menu

- After you select a Main-menu icon, if ENTER button pressed again, cursor will move to Sub-menu. Selected Sub-menu will be shown as colored.
- If you press LEFT button, value will be decreased, and if you press RIGHT button, value will be increased. You can move among Sub-menus with UP, DOWN buttons.
- To return Main-menu, move cursor to RETURN and press ENTER.

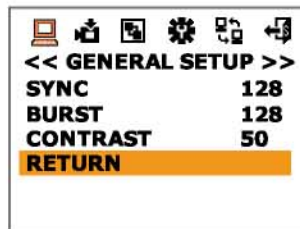
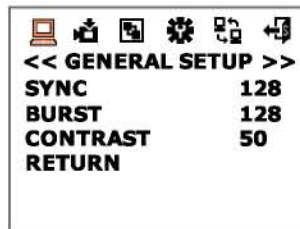

## 3. Exiting from Main-menu

- At Main-menu, move cursor to  icon, and press ENTER button.
  - SAVE AND EXIT : Camera will save the changes
  - EXIT : Camera will not save the changes.

## 1. General Setup

At Main-menu, select  icon, and press ENTER button.

- SYNC adjustment : User can adjust SYNC level (0 ~ 255)  
**SYNC 0 → 1 → .... → 255**
- BURST adjustment : User can adjust BURST level (0 ~ 255)  
**BURST 0 → 1 → .... → 255**
- CONTRAST adjustment : User can adjust CONTRAST (0 ~ 100)  
**CONTRAST 0 → 1 → .... → 100**

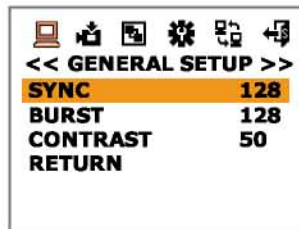





< With TDN or SDN >



< Without TDN >

## 2. Camera Setup

At main menu, select  icon, and press ENTER button.

### 2.1 AE Mode

Move cursor to AE MODE and press ENTER button.

- MODE : If you use Manual Iris lens then select ECL, and if you use Auto-Iris lens then select ALC.

**MODE            ELC → ALC**

- Lens control mode : User should properly select lens control mode.  
*In case of ELC MODE*

- AUTO : Shutter and AGC will work automatically
- MANUAL : User should select Shutter speed and AGC manually

**CONTROL        AUTO → MANUAL**

*In case of ALC MODE*

- DC : Select when you use DC Iris lens
- VSD : Select when you use VSD(Video Signal Drive) lens

**CONTROL        DC → VSD**

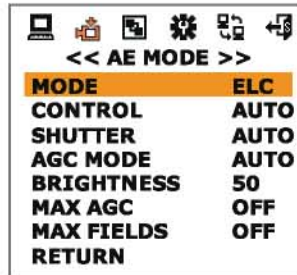

- SHUTTER : In case of ELC/Manual mode or ALC mode, user can select shutter speed between 1/60 ~ 1/100,000sec.

**SHUTTER    1/60 → .... → 1/100000**

- AGC Mode :

- AUTO : AGC will work automatically
- FIXED : AGC will be fixed as MAX AGC value

**AGC MODE    AUTO → FIXED**

- Brightness level : When using DC Iris lens, user can control the Iris of lens. Lower value will show dark video, and higher value will show bright video. It works at ELC mode also.

**BRIGHTNESS    0 → 1 → ... → 100**

- Maximum AGC : AGC will work automatically between 0 ~ Max. AGC

**MAX AGC      OFF → 8dB → ... → 36dB**

- Maximum fields of DSS (Digital slow shutter) : DSS will work automatically between Off ~ Max Field. If environmental brightness become sufficiently dark, DSS will start work.

### Note 1

According to increasing field accumulation, noise will increase also

### Note 2

It is necessary for user to decide proper Max. fields value.

**MAX FIELDS** OFF → 1FLDS → ... → 19FLDS →  
20FLDS → 40FLDS → 80FLDS →  
160FLDS → 320FLDS → 512FLDS

## 2.2 WB (White Balance) Mode

Move cursor to WB MODE and press ENTER button.

### • White Balance Mode

- AWC (Lock / Auto / CRL) : AWC mode has no color temperature range. This mode has manual (Lock) and Auto mode.
- ATW (Auto) : ATW has color temperature range of 2,500°K ~ 8,000°K.
- INDOOR : Fixed as 3200°K
- OUTDOOR : Fixed as 5400°K
- MANUAL : User can adjust RED and BLUE gain manually (0~255)

**MODE** AWC → AWC → AWC → ATW → INDOOR  
→ OUTDOOR → MANUAL

 << WB MODE >>	
<b>MODE</b>	<b>AWC</b>
CONTROL	AUTO
RED	0
BLUE	0
RETURN	

 << WB MODE >>	
<b>MODE</b>	<b>AWC</b>
CONTROL	AUTO
RED	0
BLUE	0
RETURN	

- White Balance Mode Control : "Control" display will be changed following order. Only at AWC Lock mode, you can use "CONTROL" item. During your pressing ENTER button, "LOCK" display will change to "PUSH" and white balance will work during your pressing ENTER button, and if you release ENTER button then display will change to "LOCK" again, and white balance working will stop.

**CONTROL** LOCK → AUTO → CRL → AUTO  
→ 3200 °K → 5400 °K  
→ R/B CTRL

- RED gain : At Manual mode, user can adjust RED gain.

**RED** 0 → 1 → ... → 255

- BLUE gain : At Manual mode, user can adjust BLUE gain.

**BLUE** 0 → 1 → ... → 255



&lt;&lt; BLC MODE &gt;&gt;

<b>MODE</b>	<b>BMB</b>
<b>LEVEL</b>	<b>10</b>
<b>AREA SEL</b>	<b>↶</b>
<b>BMB COLOR</b>	<b>BLACK</b>
<b>RETURN</b>	

### 2.3 BLC Mode

BLC MODE and press ENTER button.

- Backlight compensation
  - WDR (Wide Dynamic Range) function combines dark area's image and bright area's image inside memory, and makes a subject shown more clearly.
  - BMB (Black Mask BLC) function masks very bright area, and makes a subject shown more clearly.

**MODE**      **OFF → BLC → WDR → BMB**

- Level adjustment : User can adjust the level of BLC, WDR, BMB

- BLC

**LEVEL**      **0 → 1 → ... → 100**

- WDR / BMB

**LEVEL**      **0 → 1 → ... → 20**

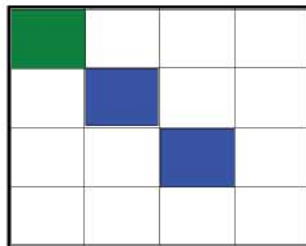

- AREA SEL : User can select area for BMB.  
If you press ENTER at AREA SEL, you can configure the area of BMB. To exit area selection menu, press the ENTER button for more than 2 seconds.
  - ALL SET : Select all area
  - ALL CLEAR : Clear all area
  - AREA SELECT : Back to area select mode
  - RETURN MENU : Exit AREA SEL, and return to BLC MODE
- BMB Color selection : User can select masking color of BMB among Black, Dark gray, Light gray, and White.

**BMB COLOR**      **BLACK → ... → WHITE**

<< PZM MODE >>	
<b>ZONE NUMBER</b>	<b>1</b>
<b>DISPLAY</b>	<b>ON</b>
<b>H SIZE</b>	<b>10</b>
<b>V SIZE</b>	<b>10</b>
<b>MOVE CONTROL</b>	<b>←</b>
<b>COLOR</b>	<b>BLUE</b>
<b>ALPHA</b>	<b>1</b>
<b>RETURN</b>	

## 2. 4 PRIVACY ZONE Masking

Move cursor to PZM MODE and press ENTER button.

- ZONE number : User can configure up to 8 PZM (Privacy Zone Mask) areas.

**ZONE NUMBER**    **1 → 2 → ... → 8**

- Display : PZM area can be displayed or not-displayed during PZM setting.

**DISPLAY**            **ON → OFF**

- Horizontal size of PZM area : User can decide the horizontal size of PZM.

**H SIZE**              **1 → 2 → ... → 768**

- Vertical size of PZM area : User can decide the vertical size of PZM.

**V SIZE**              **1 → 2 → ... → 247**

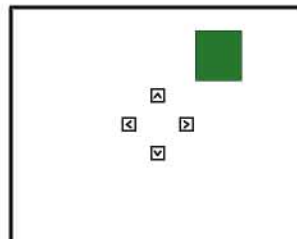
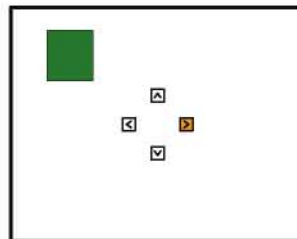

- Moving PZM area : Configured PZM area can be moved by this menu. If you press ENTER button at MOVE CONTROL, below screen will appear. You can move PZM area by UP, DOWN, LEFT, RIGHT buttons. To exit MOVE CONTROL menu, press ENTER button for more than 2 seconds.

- PZM Color : User can select color of PZM area among Black, Gray, Dark gray, White, Red, Blue, Green, Yellow, Cyan, and Magenta.

**COLOR**              **BLACK → ... → MAGENTA**

- Transparency of PZM area : Transparency of PZM area can be decided.

**ALPHA**              **0 → 1 → ... → 15**



<< NIGHTSHOT MODE >>

<b>MODE</b>	<b>OFF</b>
<b>DETECT TIME</b>	<b>5</b>
<b>SENSING</b>	<b>BRT</b>
<b>D-&gt;N LEVEL</b>	<b>2</b>
<b>N-&gt;D LEVEL</b>	<b>4</b>
<b>NIGHT COLOR</b>	<b>B/W</b>
<b>RETURN</b>	

## 2.5 NIGHTSHOT

Move cursor to NIGHTSHOT and press ENTER button.

- Night Mode : Night mode can be configured as Off, On, and Auto  
**MODE            OFF → ON → AUTO**
- Detect time : If Auto mode is selected, camera should have time interval for careful judgment.  
**DETECT TIME    0 → 1 → ... → 10**
- Detection source : The source of brightness judgment which is used by camera
  - BRT : Camera will use internal brightness value
  - CDS : Camer will use the voltage value from CDS sensor
  - ALL : Camera will use both of internal brightness value and CDS sensor output**SENSING        ALL → BRT → CDS**
- Night switching level :User can select Day to Night change sensitivity.  
**D->N LEVEL    1 → 2 → 3**



<< CAMERA ID MODE >>

<b>CAMERA ID</b>	<b>0</b>
<b>DISPLAY</b>	<b>CAM ID</b>
<b>POSITION</b>	<b>OFF</b>
ABCDEFGHIJKLM NOPQRSTUVWXYZ 0123456789!@# &<>*,;:/+ -= ~ █	
<b>TITLE :</b>	
<b>RETURN</b>	

- Day switching level : User can select Night to Day change sensitivity  
**N->D LEVEL    3 → 4 → 5**  
*N -> D LEVEL should have higher value than D -> N LEVEL*
- Night mode color : Night mode supports either B/W or Color  
**NIGHT COLOR    B / W → COLOR**

## 2.6 ID Mode

Move cursor to CAMERA ID MODE and press ENTER button.

- ID setting : ID can be configured between 0 ~ 255.  
**CAMERA ID        0 → 1 → ... → 255**
- Display : ID or camera title can be shown on monitor  
**DISPLAY            CAM ID → TITLE**
- Position : User can select the position of ID or Title.  
**POSITION          OFF → ON ←**



- Editing camera title : Supports maximum 10 characters

**TITLE :** ■■■■■■■■■■

For example, if you want to display "A" on the monitor

- First select a position with LEFT, RIGHT button. Selected position will be blinking

**TITLE :** ■

- Select "A" using UP, DOWN, LEFT, RIGHT buttons. Selected "A" will change color.

**A**BCDEFGHIJKLM  
 NOPQRSTUVWXYZ  
 0123456789 !?#  
 &<>\*,;:/+ -= ~ ■

- If you press ENTER button, camera title will have "A" now.

**TITLE :** **A** ■

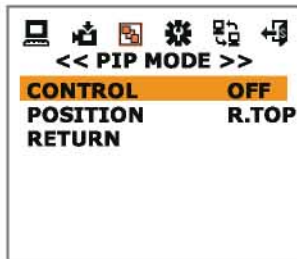
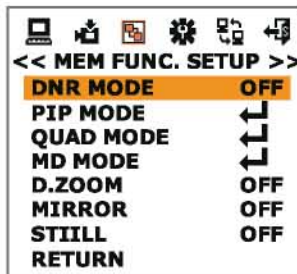

### 3. Memory Function

At main menu, select  icon, and press ENTER button.

#### 3.1 DNR Mode

DNR (Digital Noise Reduction) mode can be selected as Off, Low, High.

**DNR MODE**      **OFF → LOW → HIGH**

#### 3.2 PIP Mode

PIP (Picture-in-Picture) works when Digital zoom is working. After you make CONTROL "ON" and exit OSD menu, if you push LEFT, RIGHT buttons then digital zoom will work and you can get PIP on the screen.

- Control of PIP : This function makes PIP On/Off

**CONTROL**      **OFF → ON**

- Position of PIP : PIP display can have a position of Right-Top, Right-Bottom, Left-Top, Left-Bottom.

**POSITION**      **R.TOP → L.BOTTOM**  
                          **→ L.TOP → R.BOTTOM**

<< QUAD MODE >>	
<b>DISPLAY</b>	<b>LIVE</b>
<b>CAPTURE</b>	<b>PUSH↓</b>
<b>SEQUENCE</b>	<b>OFF</b>
<b>DWELL TIME</b>	<b>1</b>
<b>RETURN</b>	

### 3.3 QUAD Mode

QUAD Mode supports 4 split screen display. There are two working mode of "manual push" or "sequence switching" for split screen change.

- Display mode : It makes QUAD mode ON/OFF. If it is selected as LIVE, normal video will be displayed, and if it is selected as QUAD, screen will be split.

**DISPLAY            LIVE → QUAD**

- Video Capture : When DISPLAY is set as QUAD, if you push ENTER button then still image will be displayed at each split screen with clockwise direction.

- Sequence : If SEQUENCE is set as "ON" then each split screen will display still image, and still image will be changed by time interval decided at dwell time.

**SEQUENCE        OFF → ON**

- Switching time : When SEQUENCE is set as "ON", still image's refresh time can be decided by this DWELL TIME value (sec)

**DWELL TIME    1 → 2 → ... → 100**

<< MD MODE >>	
<b>MODE</b>	<b>OFF</b>
<b>AREA SEL</b>	<b>↓</b>
<b>SENSITIVITY</b>	<b>LOW</b>
<b>OUTPUT</b>	<b>ALARM</b>
<b>RETURN</b>	

### 3.4 MD (Motion Detection) Mode

Supports Motion detection and 64 areas can be selectable for working area.

- Mode : User can decide whether you will use motion detection function or not.

- Motion area : User can configure motion detection area. Area selection method is same to BMB area selection.

- Sensitivity : User can decide sensitivity of motion detection.

**SENSITIVITY    LOW → MID → HIGH**

- Output of motion detection : Motion detection has two output method. One is marking on screen "  " icon, and the other is MD signal.

**OUTPUT            ALARM → MARK**

### 3.5 Digital ZOOM function

After you select D.ZOOM, if you push LEFT, RIGHT buttons then digital zoom will work. Digital zoom can be work with PIP function.

**D.ZOOM** OFF → 1.0x → ... → 16.0x

### 3.6 Mirror function

Mirror function works as following order.

**MIRROR** OFF → H.MIRROR  
→ V.MIRROR → FLIP

### 3.7 Still function

Still function works as following order.

**STILL** OFF → ON



### 4. Special Function

At main menu, select  icon, and press ENTER button.

#### 4.1 Sharpness

Sharpness is controllable.

**SHARPNESS** 0 → 1 → ... → 15

#### 4.2 Gamma

Gamma is controllable

**GAMMA** 0.36 → ... → USER

#### 4.3 OSD language

OSD supports below 5 languages

**LANGUAGE** ENG → 한국어 → 日本語 → 簡體中文 → 繁體中文

#### 4.4 Mono

Mono function can be selected as Off, On

**MONO** OFF → ON



<< **DEFAULT SETUP** >>

**FACTORY DEFAULT**  
RETURN

## 5. Factory Default

At main menu, select  icon, and press ENTER button.  
If you press "Factory default", all data will be returned factory default values.



<< **EXIT SETUP** >>

**SAVE AND EXIT**  
EXIT  
RETURN

## 6. Exit Setup

At main menu, select  icon, and press ENTER button.

- SAVE AND EXIT : Updated data will be saved and exit menu.
- EXIT : Updated data will not be saved and exit menu.

## HVD-890NV / HVD-890PV

SPEC	High Resolution	
	HVD-890NV	HVD-890PV
Image Pick-Up Device	1/3" Sony Super HAD CCD	
Signal System	NTSC	PAL
Total Pixels	811(H) * 508(V), 410K Pixels	759(H) * 596(V), 470K Pixels
Effective Pixels	768(H) * 494(V), 380K Pixels	752(H) * 582(V), 440K Pixels
Scanning System	525 Lines, 2:1 Interlace	625 Lines, 2:1 Interlace
Sync System	Internal	
Scanning Frequency	15.734 KHz(H) 59.94 Hz(V)	15.625 KHz(H) 50 Hz(V)
Horizontal Resolution	More than 540 TV Line	
Video S/N Ratio	More than 50dB	
Minimum Illumination	Less than 0.1 lx (F1.2, 50IRE, SENS Off) Less than 0.001 lx (F1.2, 50IRE, SENS On(x 512 Fields))	

# SPECIFICATIONS

Elec. Shutter	AUTO(1/60s ~ 1/100,000s) Manual(10 Steps)	AUTO(1/50s ~ 1/100,000s) Manual(10 Steps)
AWB	ATW / AWC / IN door / OUT door / Manual	
BLC	OFF / BLC / BMB / WDR	
Gamma Correction	0.36 ~ 1 / USER, 8 Steps	
On Screen Display	On / Off	
Camera Remote control	RS-232C-TTL / RS-485(*Option)	
Lens Mount	Varifocal Lens (F2.8~10mm, FUJINON, YV3.6x2.8A-SANY)	
ALC	EE / VSD / DC	
Video Output	Composite Video Signal 1Vp-p, 75Ω Drives, BNC Output	
Power Source	DC 12V (10V ~ 14V)	
Current Consumption	Less than 200mA	
Operating Temperature	-10 ~ 50℃	
Storage Temperature	-20 ~ 70℃	
Weight	1.5kg	
Dimension(H x V x D)	138 x 138 x 132.5mm	

# SPECIFICATIONS

## HVD-890NT / HVD-890PT

SPEC	Model	
	HVD-890NT	HVD-890PT
Image Pick-Up Device	1/3" Sony Super HAD CCD	
Signal System	NTSC	PAL
Total Pixels	811(H) * 508(V), 410K Pixels	759(H) * 596(V), 470K Pixels
Effective Pixels	768(H) * 494(V), 380K Pixels	752(H) * 582(V), 440K Pixels
Scanning System	525 Lines, 2:1 Interlace	625 Lines, 2:1 Interlace
Sync System	Internal	
Scanning Frequency	15.734 KHz(H) 59.94 Hz(V)	15.625 KHz(H) 50 Hz(V)
Horizontal Resolution	More than 540 TV Line	
Video S/N Ratio	More than 50dB	
Minimum Illumination	Less than 0.1 lx (F1.2, 50IRE, TDN Off, SENS Off) Less than 0.01 lx (F1.2, 50IRE, TDN On, SENS Off) Less than 0.001 lx (F1.2, 50IRE, TDN Off, SENS On(x 512 Fields)) Less than 0.0001 lx (F1.2, 50IRE, TDN On, SENS On(x 512 Fields))	



# SPECIFICATIONS

Elec. Shutter	AUTO(1/60s ~ 1/100,000s) Manual(10 Steps)	AUTO(1/50s ~ 1/100,000s) Manual(10 Steps)
AWB	ATW / AWC / IN door / OUT door / Manual	
BLC	OFF / BLC / BMB / WDR	
Day & Night	On / Off / Auto	
Gamma Correction	0.36 ~ 1 / USER, 8 Steps	
On Screen Display	On / Off	
Camera Remote control	RS-232C-TTL / RS-485(*Option)	
Lens Mount	Varifocal Lens (F2.8~10mm, FUJINON, YV3.6x2.8R5D-SANY)	
ALC	EE / VSD / DC	
Video Output	Composite Video Signal 1Vp-p, 75Ω Drives, BNC Output	
Power Source	DC 12V (10V ~ 14V)	
Current Consumption	Less than 200mA	
Operating Temperature	-10 ~ 50 °C	
Storage Temperature	-20 ~ 70 °C	
Weight	1.5kg	
Dimension(H x V x D)	138 x 138 x 132.5mm	

# SPECIFICATIONS

## HVD-890NI / HVD-890PI

SPEC	Model	
	HVD-890NI	HVD-890PI
Image Pick-Up Device	1/3" Sony Super HAD CCD	
Signal System	NTSC	PAL
Total Pixels	811(H) * 508(V), 410K Pixels	759(H) * 596(V), 470K Pixels
Effective Pixels	768(H) * 494(V), 380K Pixels	752(H) * 582(V), 440K Pixels
Scanning System	525 Lines, 2:1 Interlace	625 Lines, 2:1 Interlace
Sync System	Internal	
Scanning Frequency	15.734 KHz(H) 59.94 Hz(V)	15.625 KHz(H) 50 Hz(V)
Horizontal Resolution	More than 540 TV Line	
Video S/N Ratio	More than 50dB	
Minimum Illumination	Less than 0.1 lx (F1.2, 50IRE, TDN Off, SENS Off) Less than 0.01 lx (F1.2, 50IRE, TDN On, SENS Off) Less than 0.001 lx (F1.2, 50IRE, TDN Off, SENS On(x 512 Fields)) Less than 0 lx (IR LED ON)	

Elec. Shutter	AUTO(1/60s ~ 1/100,000s) Manual(10 Steps)	AUTO(1/50s ~ 1/100,000s) Manual(10 Steps)
AWB	ATW / AWC / IN door / OUT door / Manual	
BLC	OFF / BLC / BMB / WDR	
Day & Night	On / Off / Auto	
Gamma Correction	0.36 ~ 1 / USER, 8 steps	
On Screen Display	On / Off	
Camera Remote control	RS-232C-TTL / RS-485(*Option)	
Lens Mount	Varifocal Lens (F2.8~10mm, FUJINON, YV3.6x2.8R5D-SANY)	
ALC	EE / VSD / DC	
Video Output	Composite Video Signal 1Vp-p, 75Ω Drives, BNC Output	
IR LED	5Ø, 60 Degree, 850nm, 24pcs	
Power Source	DC 12V (10V ~ 14V)	
Current Consumption	Less than 200mA (IR ON : 260mA)	
Operating Temperature	-10 ~ 50 °C	
Storage Temperature	-20 ~ 70 °C	
Weight	1.5kg	
Dimension(H x V x D)	138 x 138 x 132.5mm	